

Deck to be landed on scaffold platform positioned around the perimeter. Packs shown indicatively on the frame so that the packs can be landed as close to this position as practically possible

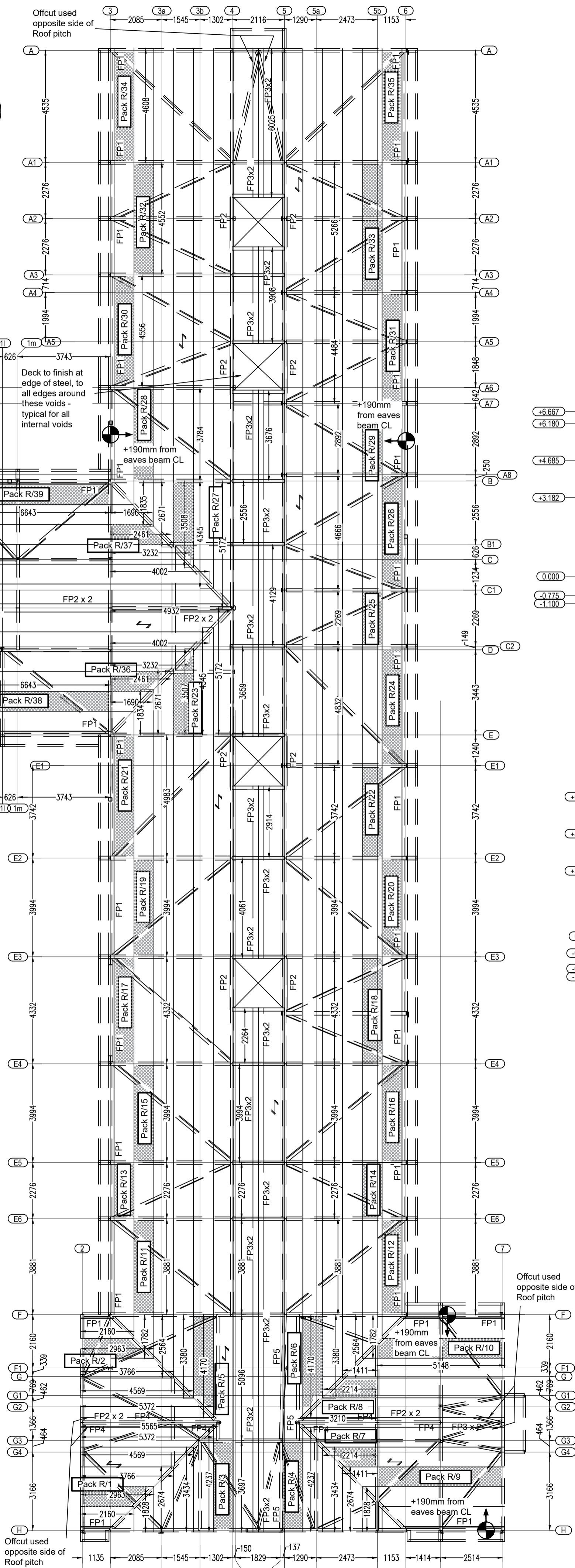

Deck to be fixed using ENP shot fired fixings

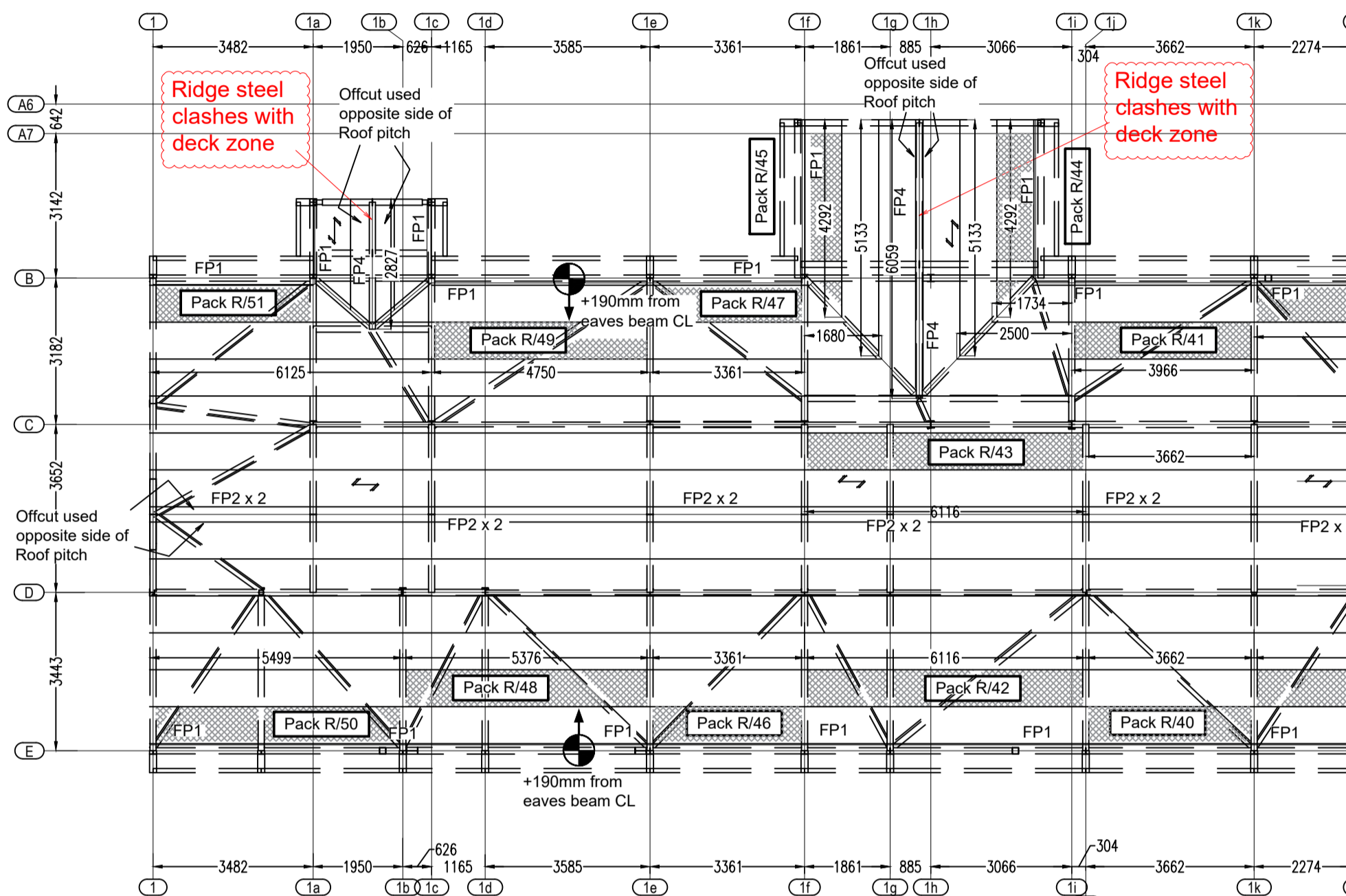
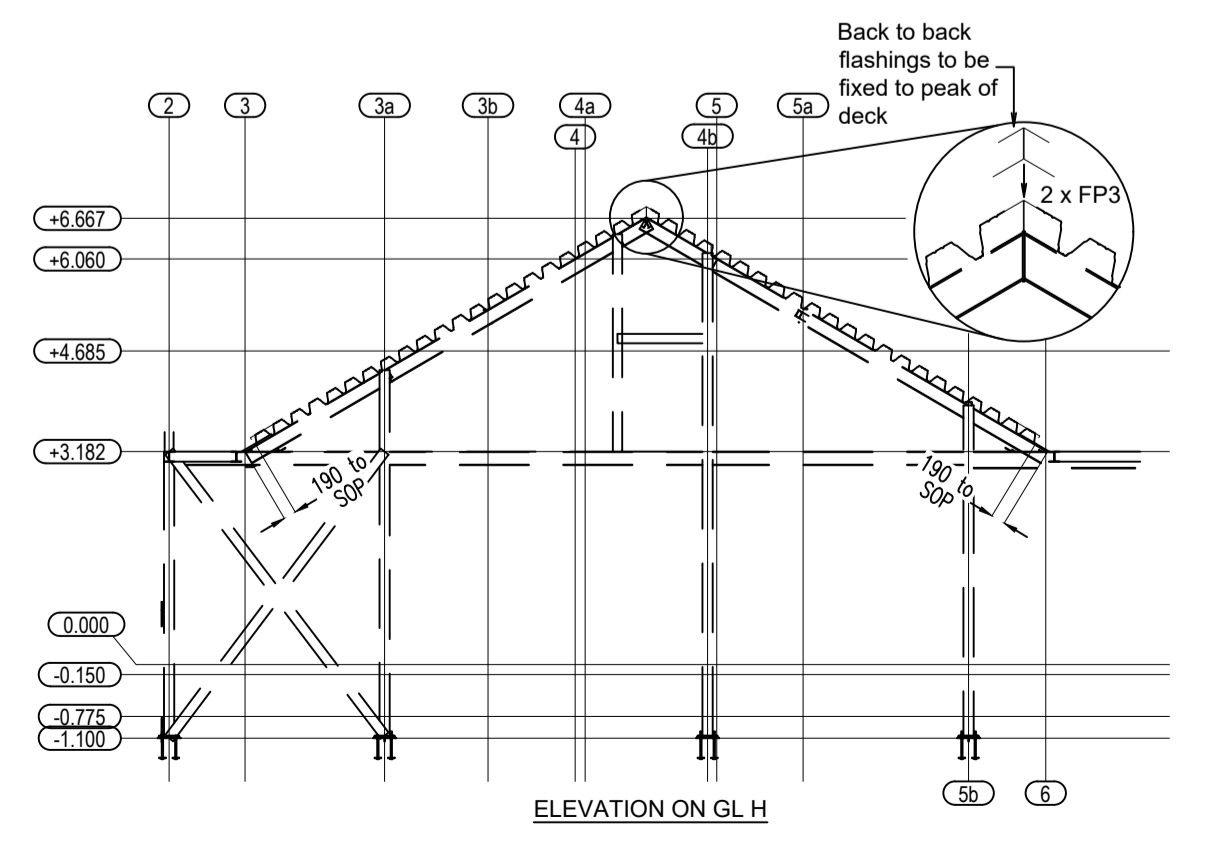
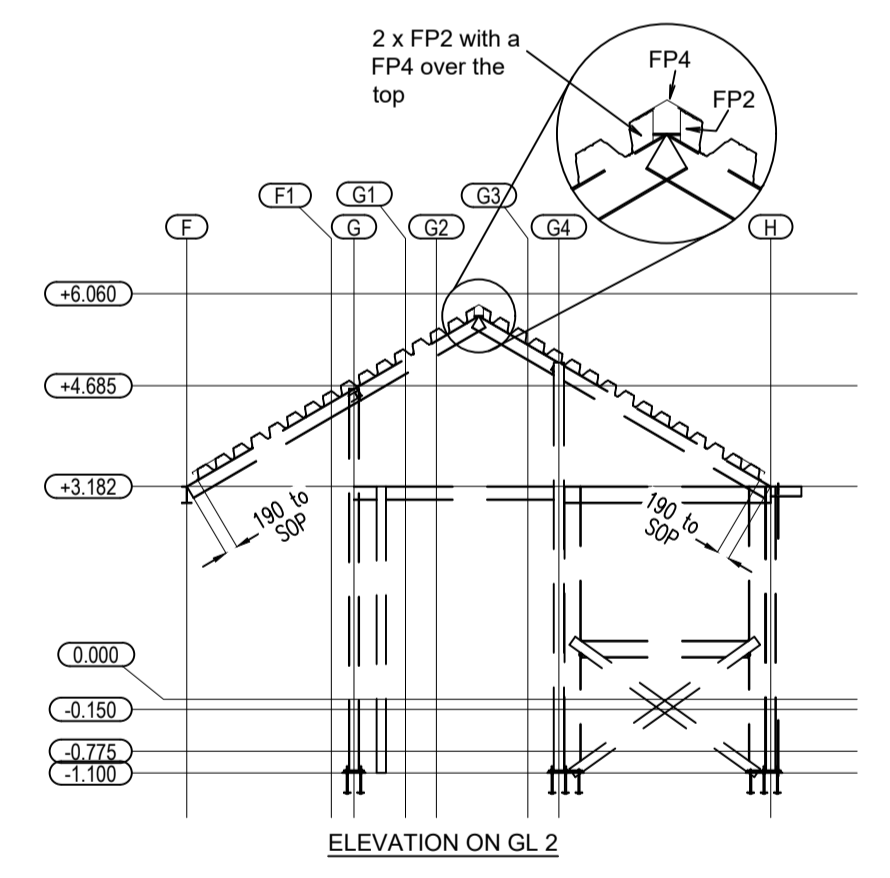
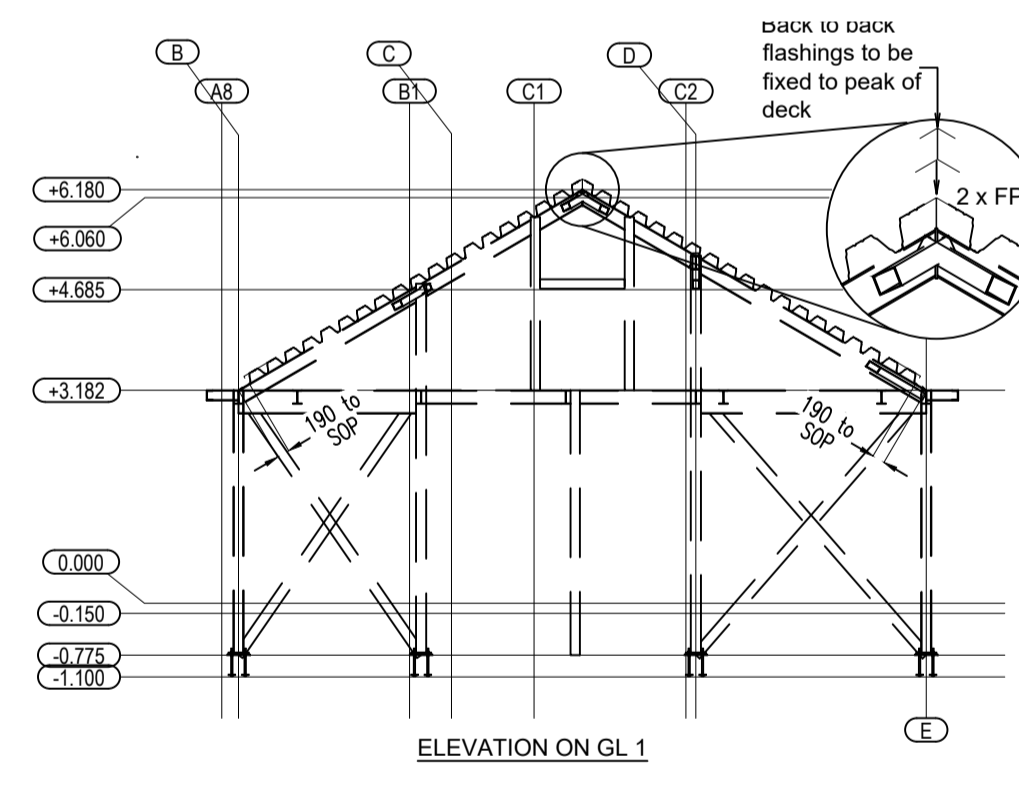
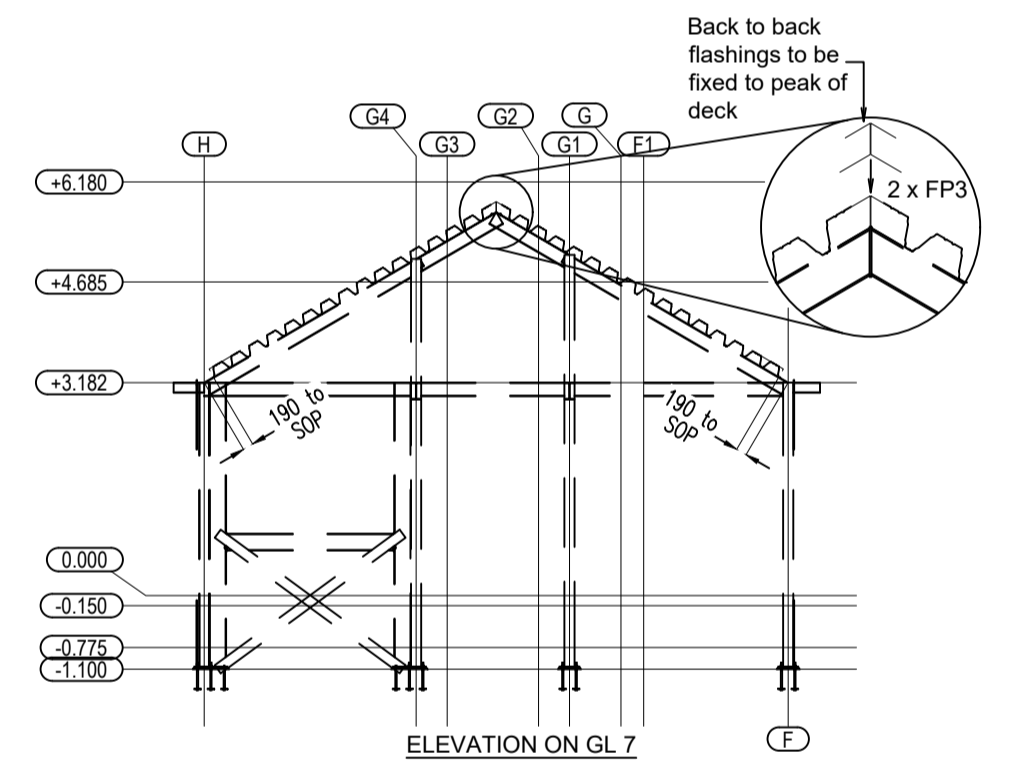
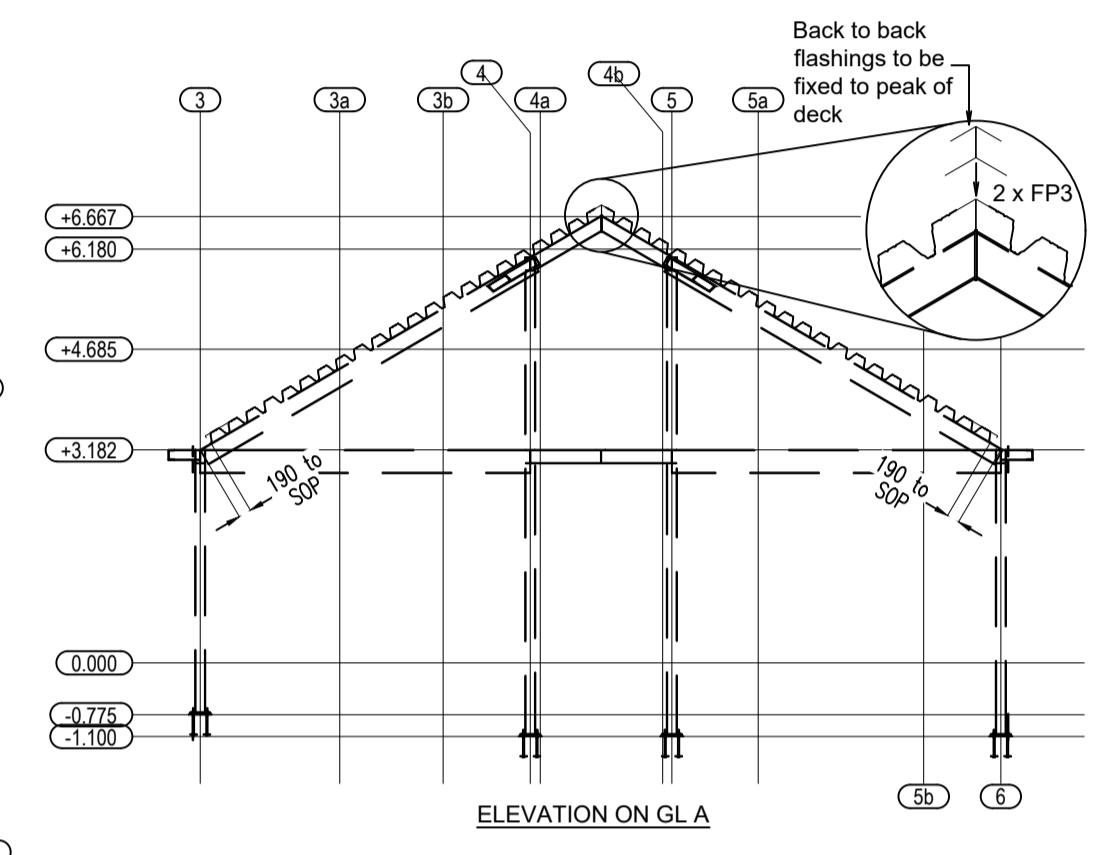

Installers Note
 Fix deck to edge stiffener at 500mm centres longitudinally

